



P: 866.733.0233  
www.solerpalaucanada.com

# MODEL TDB (Sizes 12 & 16) BELT DRIVE TUBEAXIAL DUCT FANS

## STANDARD FEATURES

- Heavy-gauge rolled steel construction.
- Integral inlet and outlet flanges with mounting holes.
- Continuous welded and epoxy coated.
- Belt and bearing tube.
- Removable bearing cover for ease of maintenance.
- Eight mounting supports welded to each fan.
- Adjustable motor base for belt tensioning.
- Extended lube lines.
- Aluminum airfoil propeller.
- Sized for minimum 150% of drive horsepower.
- Bearings are designed for minimum 200,000 hour life, L50.
- Cast iron self-aligning pillow block ball bearings.
- Bearings are sealed and prelubricated.
- AMCA Air and Sound Certified
- cULus 705 Listed

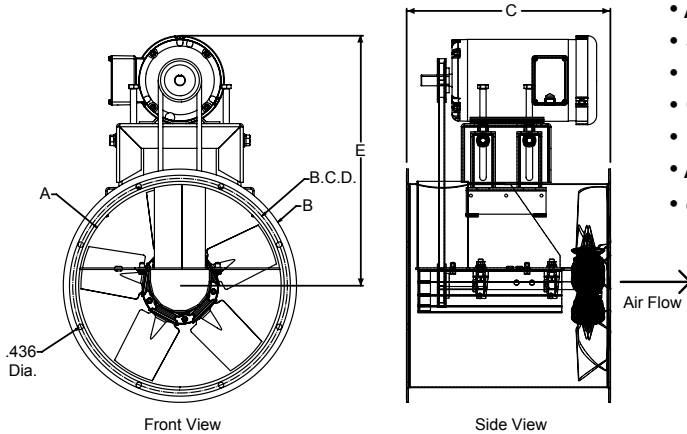

Model No.	Housings			B.C.D.	E (Max)	Holes		Max Motor Frame	Steel Housing Gauges	Avg. Ship Wt. (Lbs)
	I.D. A	O.D. B	Length C*			Dia.	#			
12	12-3/8	14-1/2	12	13-1/2	21	5/8"	6	145T	16	90
16	16-3/8	18-1/2	17	17-3/8	23	7/16"	8	145T	16	110

\*Motor may extend past unit

**NOTE: All dimensions shown are in inches.**

FAN SPECIFICATIONS									MOTOR SPECIFICATIONS				
Line	Qty.	Model No.	Tag	CFM	SP	Fan RPM	BHP	Sones	HP	Volts	Phase	Hertz	Encl
1													
2													
3													
4													
5													

ACCESSORY ITEMS					ACCESSORY ITEMS						
	1	2	3	4	5		1	2	3	4	5
<input type="checkbox"/>						<input type="checkbox"/>					
<input type="checkbox"/>						<input type="checkbox"/>					
<input type="checkbox"/>						<input type="checkbox"/>					
<input type="checkbox"/>						<input type="checkbox"/>					
<input type="checkbox"/>						<input type="checkbox"/>					

Subject to change unless approved in submittal by S&P.

TDB12-16\_Submittal

